

# Dane techniczne

CR, CRE 32

Rysunek wymiarowy

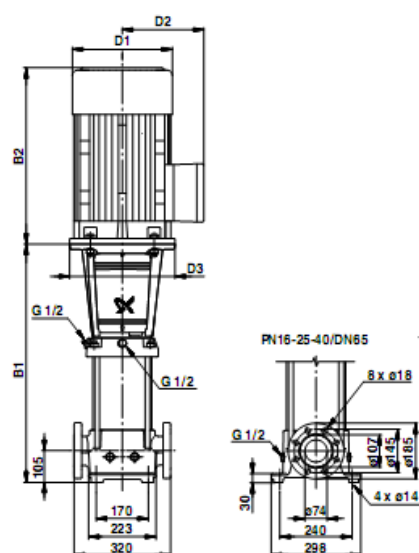

TM0117493268

Wymiary i masa

Typ pompy	Moc silnika P <sub>2</sub> [kW]	CR					CRE						
		Wymiary [mm]					Masa netto [kg]	Wymiary [mm]					Masa netto [kg]
		B1	B1+B2	D1	D2	D3		B1	B1+B2	D1	D2	D3	
CR(E) 32-1-1	1,5	505	786	178	110	270	64	505	786	178	167	270	70
CR(E) 32-1	2,2	505	826	178	110	270	64	505	826	178	167	270	74
CR(E) 32-2-2	3	575	910	198	120	270	71	575	910	198	177	270	81
CR(E) 32-2	4	575	947	220	134	270	82	575	947	220	188	270	92
CR 32-3-2	5,5	645	1036	220	134	300	96	-	-	-	-	-	-
CR(E) 32-3	5,5	645	1036	220	134	300	96	645	1036	220	188	298	103
CR 32-4-2	7,5	715	1106	220	134	300	101	-	-	-	-	-	-
CR(E) 32-4	7,5	715	1106	220	134	300	101	715	1106	220	188	298	109
CR 32-5-2	11	895	1394	260	172	350	139	-	-	-	-	-	-
CR 32-5	11	895	1394	260	172	350	139	-	-	-	-	-	-
CR 32-6-2	11	965	1464	260	172	350	142	-	-	-	-	-	-
CR(E) 32-6	11	965	1464	260	172	350	142	965	1414	258	359	350	194
CR 32-7-2	15	1035	1513	320	197	350	163	-	-	-	-	-	-
CR 32-7	15	1035	1513	320	197	350	163	-	-	-	-	-	-
CR 32-8-2	15	1105	1583	320	197	350	169	-	-	-	-	-	-
CR(E) 32-8	15	1105	1583	320	197	350	169	1105	1566	313	377	350	220
CR 32-9-2	18,5	1175	1693	320	197	350	180	-	-	-	-	-	-
CR 32-9	18,5	1175	1693	320	197	350	180	-	-	-	-	-	-
CR 32-10-2	18,5	1245	1763	320	197	350	183	-	-	-	-	-	-
CR(E) 32-10	18,5	1245	1763	320	197	350	183	1245	1744	313	377	350	262
CR 32-11-2	22	1315	1925	363	262	350	272	-	-	-	-	-	-
CR 32-11	22	1315	1925	363	262	350	272	-	-	-	-	-	-
CR 32-12-2	22	1385	1995	363	262	350	276	-	-	-	-	-	-
CR(E) 32-12	22	1385	1995	363	262	350	276	1385	1910	351	399	350	308
CR 32-13-2	30	1455	2101	415	300	400	329	-	-	-	-	-	-
CR 32-13	30	1455	2101	415	300	400	329	-	-	-	-	-	-
CR 32-14-2	30	1525	2171	415	300	400	332	-	-	-	-	-	-
CR 32-14	30	1525	2171	415	300	400	332	-	-	-	-	-	-